

BC190XL BRUSH CHIPPER



BUILT TO LAST. Market-leading oversized cutter bearings, disc, drive and infeed system mounted in a high-strength all-steel body to provide the productivity needed for your demanding workloads.



MARKET-LEADING INFEEED. A large infeed opening of 203x305 mm in combination with a wide tapered infeed table provides the capacity to do the hard work for you.



PUSH-BUTTON CHIPPING. Convenient operation with one switch to engage the throttle and one switch to engage the cutter disc, with indicator light.



LARGEST INFEEED ROLLERS IN CLASS. With an offset 400 mm top roller and 260 mm bottom roller combined with Vermeer-exclusive auto reversing SmartFeed control, feeding material becomes much more convenient.



NO-COMPROMISE CHIPPING. Coupling the Kubota 48,1 hp (35,9 kW) engine to a 76 cm diameter 4-knife disc, the BC190XL can handle diameters up to 20 cm and discharges chips at an average distance from 10 to 12 metres - all this at 120 dB(A)!



3-YEAR WARRANTY. The Vermeer BC190XL comes standard with a 3-year limited warranty. Ask your local Vermeer dealer for the details.



VERMEER.COM

Vermeer



**EQUIPPED TO
DO MORE.**

BC190XL BRUSH CHIPPER

Available only through select Vermeer dealers for sale into European Community.

GENERAL WEIGHTS AND DIMENSIONS

Weight: 1480 kg

Length (transport): 3740 mm

Width (transport): 1530 mm

Height (transport): 2480 mm

Infeed opening width: 305 mm

Infeed opening height: 203 mm

ENGINE

Make and model: Kubota V2203-M-E3B

Fuel type: Diesel

Gross horsepower: 48,1 hp (35.9 kW)

Max torque: 145 Nm

Number of cylinders: 4

Cooling method: Liquid

Sound power: 120 dB(A)

FLUID CAPACITIES

Fuel tank: 56 L

Hydraulic tank: 22,7 L

FEED SYSTEM

Top feed roller diameter: 400 mm

Bottom feed roller diameter: 260 mm

Orientation: Horizontal

Infeed table width: 1120 mm

CHASSIS

Axle/Suspension: Alko Plus 1500 kg

Tires: 175R14C8PR

Surgebrake: Mechanical

OPTIONS

Special paint

Extended warranty

Vermeer Confidence Plus® asset protection program

DISC

Weight: 120 kg

Diameter: 760 mm

Speed: 1480 rpm

Knives: Four double-edged knives

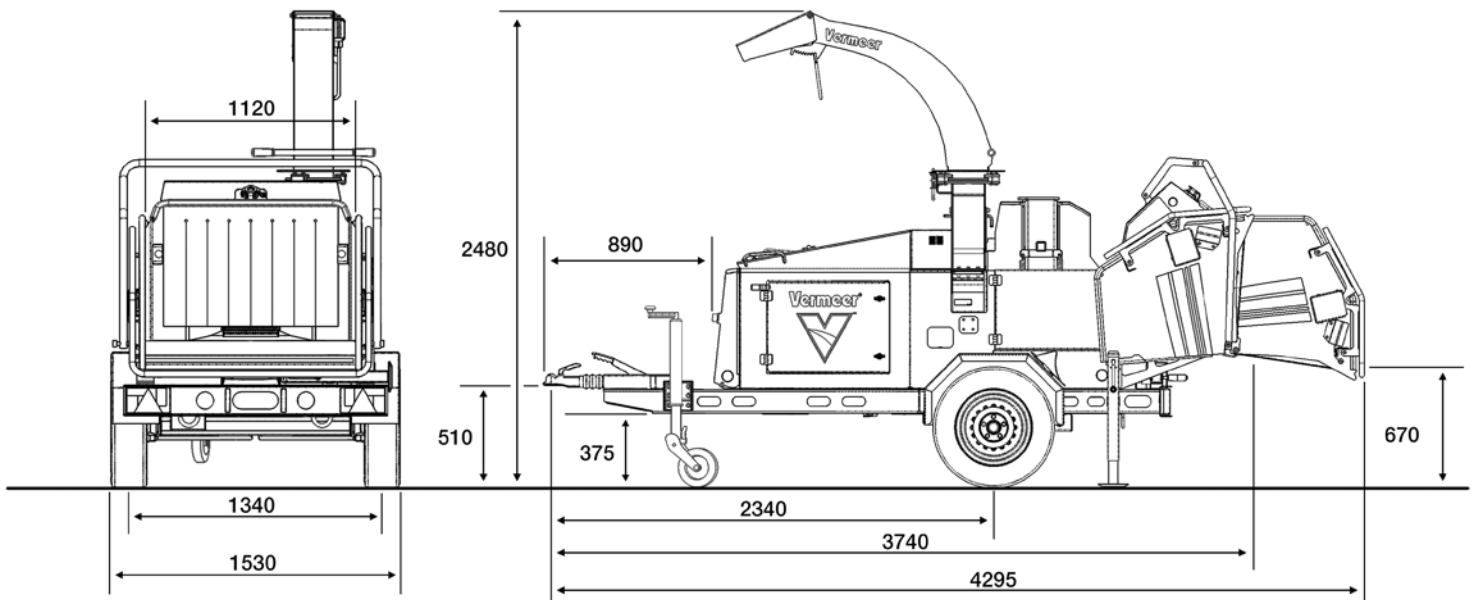

* measurements are in mm and may vary +/- 5mm

NOTES:

Vermeer Manufacturing International Goes reserves the right to make changes in engineering, design and specifications; add improvements; or discontinue manufacturing at any time without notice or obligation. Equipment shown is for illustrative purposes only and may display optional accessories or components specific to their global region. Please contact your local Vermeer dealer for more information. Vermeer, the Vermeer logo, Equipped to Do More and Vermeer Confidence Plus are trademarks of Vermeer Manufacturing Company in the U.S. and/or other countries. © 2019 Vermeer Manufacturing International Goes. All Rights Reserved.



EQUIPPED TO
DO MORE.™